



Roblan Pty Ltd

A.B.N. 74 000 595 415



Sydney Office
Unit 1, 2 Heald Road
Ingleburn NSW 2565

Phone: 02 9605 7628
Fax: 02 9605 6126

Press Shop Automation Division

www.roblan.com.au

Melbourne Office
1A Capital Court
Braeside VIC 3195

Phone: 03 9587 8833
Fax: 03 9587 6788

Market Announcement

Dayton Progress Corporation Acquires Lane Punch Corporation.

Roblan Pty Limited have been advised that the Assets and Business of Lane Punch Corporation have been Purchased by Dayton Progress Corporation as of 1st February 2011.

Attached is a copy of the official communication from Wahl Marketing.

Dayton Progress is the world's largest punch manufacturer with plants in the USA, Canada, Japan, UK, France and Germany.

Dayton Progress is discontinuing the supply of Lane products in the Asia-Pacific region, except for special automotive projects.

Lane Punch products and Dayton Progress punch products are interchangeable.

Roblan Pty Limited, as Dayton's Australian Distributor, are able to offer the full range previously supplied from Lane Punch Corporation. Roblan have represented Dayton Progress in Australia for over 30 years, and are specialists in the supply of metal stamping punches. Roblan are able to accept orders with the Lane part numbers. These will be converted to Dayton part numbers to help with the process of change.

If you have any questions or need help in placing your punch orders, please do not hesitate to contact us.

Yours Faithfully

Eric Martin
Managing Director

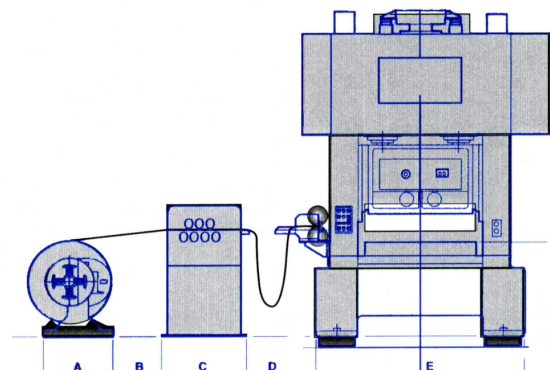

Wahl Marketing Communications

6250 Lakota Drive Cincinnati, OH 45243
(513) 561-2002 – Phone (513) 561-0814 – Fax
jim@wahlmarketing.com

For Immediate

For More Information

Release

February 1, 2011

Contact:

Jim Wahl
Wahl Marketing
(513) 561-2002
jim@wahlmarketing.com

Bob Hedrick
Dayton Progress, Inc.
(937) 859-5111
bhedrick@daytonprogress.com

Dayton Progress Corporation Acquires the Business and Assets of Lane Punch Corporation

Dayton, OH – Dayton Progress Corporation, headquartered in Dayton, Ohio has acquired the business and assets of Lane Punch Corporation. Lane Punch, a manufacturer of metal stamping tools, was established in 1965 and has manufacturing locations in Michigan and North Carolina. During 2011 Dayton progress will transfer all production from the two Lane plants to Dayton Progress factories in Ohio, Canada, Mexico, Europe and Asia, nearer to the customers of Lane.

“The purchase of Lane Punch greatly enhances Dayton’s position as the industry leader in the Metal Stamping and Forming Tooling industry”, said Alan Shaffer, President & CEO of Dayton Progress. “Dayton Progress is in its 65th year of tool making excellence, innovative products, and outstanding customer service.”

Dayton Progress is a recognized leader for manufacturing and supplying tools and accessories to the Metal Stamping and Metal Forming industries globally. Dayton’s more than 800 employees ship millions of tools each year from its 10 factories in North America, Europe and Asia to 20,000 customers in 70 countries.

Dayton Progress is the world-wide leader in the manufacture of catalog and special punches, punch blanks and other precision tooling. They provide single source convenience for tooling in both standard-inch and metric sizes. In addition to a full standard line of precision punches, pilots, die buttons and retainers in configurations to suit any manufacturing requirements, the company also manufactures nanoceramic grease, as well as custom tooling.

For additional information visit them online at www.daytonprogress.com, or e-mail them at info info@daytonprogress.com or call (937) 859-5111. Write to Dayton Progress, 500 Progress Road, PO Box 39, Dayton, OH 45449-0039.