

EZ Fit™ Ball Lock Retainer Inserts

Inch & Metric



Dayton EZ Fit™ Ball Lock Retainer Inserts give you the ability to reconfigure and custom-make retainers in-house as die specifications change. The unique single-piece teardrop shape, combined with both a straight and an angled wedge side, holds your ball lock punch securely in place. EZ Fit™ Inserts reduce costs and downtime—and simplify tooling changeover.

A Simpler, Better Way

Cost-effective.
Innovative,
New Design

EZ Fit™ Inserts



Global leader in
providing fabrication
and stamping solutions

Subsidiary Federal Signal Corporation 

www.daytonprogress.com



INCH

HRI
Heavy Duty

LRI
Light Duty

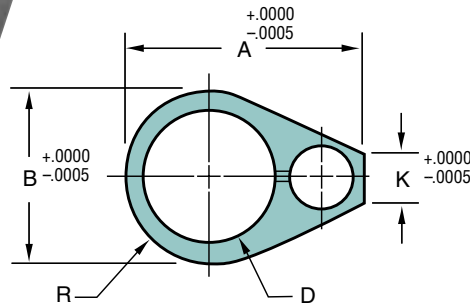

Ball hole location radial tolerance $\pm 0^{\circ}5'$

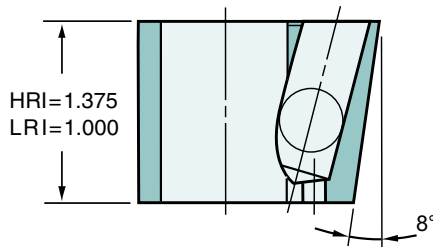

Heavy Duty

Type	Punch Hole Dia. D	Code	A	B	K
HRI	0.3750	37	1.0630	0.6250	0.3882
	0.5000	50	1.3190	0.7500	0.5250
	0.6250	62	1.4570	0.9000	0.4698
	0.7500	75	1.6040	1.0600	0.4202
	0.8750	87	1.7320	1.1950	0.4182
	1.0000	100	1.8700	1.3200	0.4111
	1.2500	125	2.1260	1.5700	0.3951

Light Duty

Type	Punch Hole Dia. D	Code	A	B	K
LRI	0.2500	25	0.7750	0.4375	0.3125
	0.3750	37	0.9000	0.5625	0.3125
	0.5000	50	1.1200	0.7500	0.3125
	0.6250	62	1.2500	0.8750	0.3125
	0.7500	75	1.4700	1.0700	0.3125
	0.8750	87	1.6000	1.1950	0.3125
	1.0000	100	1.7200	1.3200	0.3125

Build New or Modify Existing Retainers—Quickly & Easily

Dayton EZ Fit™ Inserts provide a simple, low-cost solution to *building* new dies because the inserts utilize a revolutionary design that assures a positive, rigid, and more accurate fit than other inserts on the market.

One side of the insert is cut at an 8° angle to create a wedge shape that—when combined with the teardrop shape—assures that the insert and retainer fit together as a single unit. (See cutaway.)



EZ Fit™ Inserts are also ideal for *repairing or making engineering changes*. When changes occur—and the location(s) of the punches in the die set change(s)—new or reconfigured retainers are required. In-house modification can slow the changeover process; often requires specialized equipment and knowledge; and the integrity of the original retainer can be compromised.

Now—with the help of the all-new Dayton EZ Fit™ Ball Lock Retainer Insert—building new or repairing/retrofitting existing retainers can be simplified and completed in-house at a fraction of the cost of replacing existing retainers!



1 Day

HOW TO ORDER

Specify:	Qty.	Type	Code
Example:	5	HRI	37
	12	LRI	62



In-house Modifications

Dayton EZ Fit™ Retainer Inserts can be used to change hole locations in Multi-Position™ Retainers, thus allowing reuse of existing retainers. The process is quick, easy, effective, and far less expensive than part replacement costs. To retrofit, simply wire cut the hole to the specified size. Wire cut EDM instructions included with each insert, and are available at www.daytonprogress.com/EZFit

Tighter Tolerances. Optimum Performance.

Dayton EZ Fit™ Inserts are designed to assure tighter, more precise tolerances than other retainer inserts.

The EZ Fit™ unique teardrop shape provides a *single, tightly secured receptacle* for the punch. One side of the piece (the flat side) is cut at an 8° angle to create a wedge shape. The hole in the retainer is wire cut to create a snug fit.

Wire Cut EDM

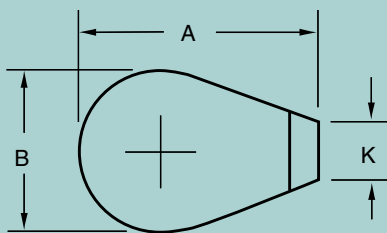

Each insert comes complete with wire cutting instructions that show recommended dimensions and tolerances for optimum performance. Wire cutting instructions are also available online at www.daytonprogress.com/EZFit

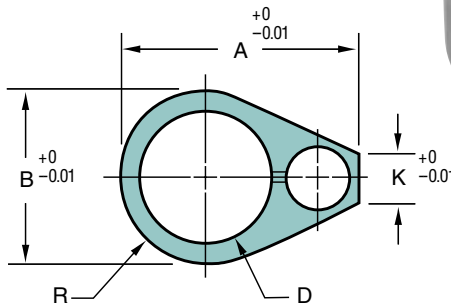

Ball hole location radial tolerance $\pm 0^{\circ}5'$

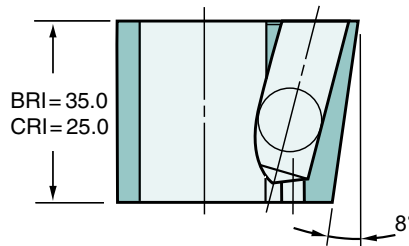

BRI
Heavy Duty
CRI
Light Duty

Heavy Duty

Type	Punch Hole Dia. D	Code	A	B	K
BRI	10	10	27.5	16.0	10.89
	13	13	33.0	19.5	12.26
	16	16	36.4	23.0	11.06
	20	20	40.7	27.5	9.88
	25	25	46.0	33.0	9.42
	32	32	53.2	40.0	8.92
	40	40	61.4	48.0	8.54

Light Duty

Type	Punch Hole Dia. D	Code	A	B	K
CRI	06	06	19.60	11.10	7.90
	10	10	24.80	15.60	7.90
	13	13	28.40	19.00	7.90
	16	16	31.60	22.00	7.90
	20	20	36.20	27.00	7.90
	25	25	41.40	32.40	7.90
	32	32	48.70	40.00	7.90



1 Day

HOW TO ORDER

Specify:	Qty.	Type	Code
Example:	5	BRI	13
	12	CRI	25

Dayton Progress Corporation
500 Progress Road
P.O. Box 39
Dayton, OH 45449-0039 USA

Dayton Progress Portland
1314 Meridian St.
Portland, IN 47371 USA

Dayton Progress Canada, Ltd.
861 Rowntree Dairy Road
Woodbridge, Ontario L4L 5W3

Dayton Progress, Ltd.
G1 Holly Farm Business Park
Honiley, Kenilworth
Warwickshire CV8 1NP UK

Dayton Progress Corporation of Japan
2-7-35 Hashimotodai
Sagamihara-Shi, Kanagawa-Ken
229-1132 Japan

Dayton Progress GmbH
Im Heidegraben 8
Postfach 1165
61401 Oberursel/Ts., Germany

Dayton Progress Perfuradores Lda
Zona Industrial de Casal da Areia Lote 17
Cós, 2460-392 Alcobaça, Portugal

Dayton Progress SAS
105 Avenue de l'Épinette
BP 128
Zone Industrielle
77107 Meaux Cedex, France

Federal Signal Tool (Dongguan) Ltd.
Bu Bu Gao Avenue, Jiang Bei
Wusha Community, Changan
Dongguan, China

Dayton Progress Czech sro
Hala G
Pražská 707
CZ-294 71 Benátky nad Jizerou
Czech Republic



Global leader in providing fabrication and stamping solutions